



HM-30 Pump Panel Module

Installation Guide



17600 SW 65th Ave, Lake Oswego, OR 97035 USA
800-527-0555 • firecom.com

HM-30 Pump Panel Module Installation Guide

Tools Needed

- Crimp tool for RJ12 connectors (not included, part# 108-0023-00)
- ½ inch drill bit for CA Cable (not included)
- Drill (not included)
- Screwdriver with #2 Phillips bit (not included)
- #29 drill bit or 1/8 inch bit is acceptable (not included)

Contents

- HM-30 module
- 75' of 6c flat cable (installed)
- RJ connector (installed)
- 2 spare RJ connectors
- Installation Guide



HM-30 Module Installation Steps

1. Observe the location desired to mount the module.
Note: Use caution of location that is being drilled as to not damage anything behind the metal.
2. Reference the diagrams for the HM-30 dimensions and mark the mounting screw locations on your installation surface. Also, mark the location of the CA cable hole.
3. Drill pilot holes for the mounting screws with the #29 drill bit (1/8 inch size bit acceptable) and also drill a 1/2 inch pilot hole at the same time for the CA cable.
4. Secure HM-30 module with provided screws to pump panel.
5. Route HM-30 flat CA Cable to the Firecom intercom.
6. Plug the RJ12 connector into the desired intercom port on the back of the Firecom intercom.

HM-30 Diagrams

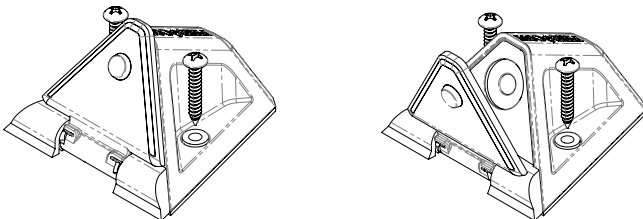
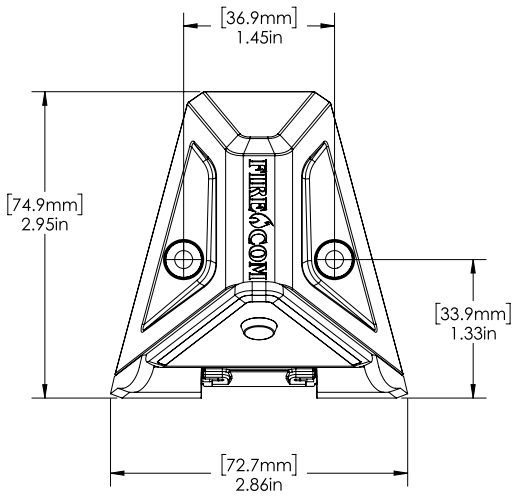
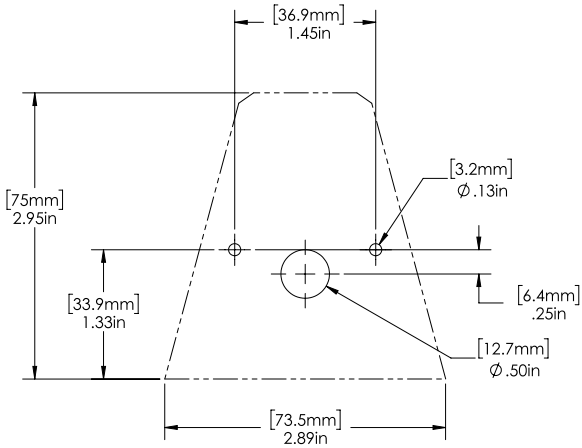

Modular Plug Installation Steps

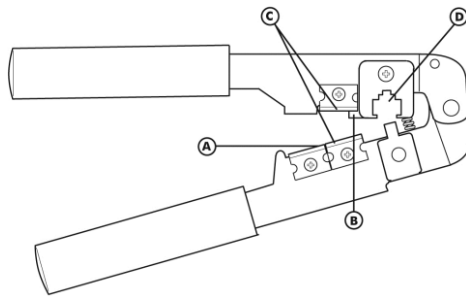

1. Using the cutter blade on the crimping tool (A), cut the flat CA Cable so the cut is clean and 90 degrees to the sides of the cable.
2. Insert one end of the CA Cable between the stripping blades (C) until the end of the cable hits the stop (B).
3. Squeeze the handles of the crimping tool together until the tool bottoms out.
4. While holding the handles together, pull the cable out of the tool.
5. The stripped insulation should expose approximately 3/16" of wire.

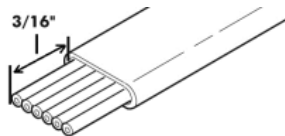

6. Push a RJ Modular Plug into the plug holder on the crimping tool (D) until the release tab on the plug locks into position.
7. Holding the cable so it's orientated like in *Figure 1* from the Wiring Diagram section below, push the cable into the plug as far as it will go.
8. Squeeze the tool handles **COMPLETELY** together. You may feel the crimper finish punching the contacts through the insulation on the wires.
9. Let the handles spring open.
10. Push down on the release-tab on the RJ Modular Plug and remove the RJ Modular Plug from the crimping tool.
11. Inspect the plug to ensure that the cable is held securely in place.

Wiring Diagram

In the event the modular plug is removed, please reference the diagram below:

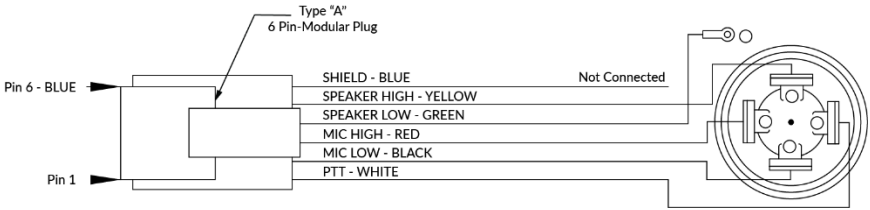

Figure 1

Page intentionally left blank

Firecom, a division of Sonetics Corporation

Copyright ©2020 Sonetics Corporation. All rights reserved.
The information in this document is subject to change without notice.

600-0090-00 Rev A
